

Phase Control Thyristor

$$V_{RRM} = 1200-1600 \text{ V}$$

$$I_{T(RMS)} = 75 \text{ A}$$

$$I_{T(AV)M} = 48 \text{ A}$$

Preliminary Data Sheet

V_{RSM}	V_{RRM}	Type
V_{DSM}	V_{DRM}	
V	V	
1300	1200	CS 60-12io1
1500	1400	CS 60-14io1
1700	1600	CS 60-16io1

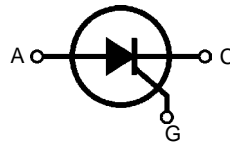

PLUS247

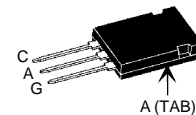

C = Cathode, A = Anode, G = Gate

Symbol	Test Conditions	Maximum Ratings	
$I_{T(RMS)}$	$T_{VJ} = T_{VJM}$ (lead current limit)	75 A	
$I_{T(AV)M}$	$T_C = 105^\circ\text{C}$; 180° sine	48 A	
I_{TSM}	$T_{VJ} = 45^\circ\text{C}$; $V_R = 0 \text{ V}$	t = 10 ms (50 Hz), sine t = 8.3 ms (60 Hz), sine	1500 A 1600 A
	$T_{VJ} = T_{VJM}$; $V_R = 0 \text{ V}$	t = 10 ms (50 Hz), sine t = 8.3 ms (60 Hz), sine	1350 A 1450 A
i^2t	$T_{VJ} = 45^\circ\text{C}$; $V_R = 0 \text{ V}$	t = 10 ms (50 Hz), sine t = 8.3 ms (60 Hz), sine	11,200 A ² s 10,750 A ² s
	$T_{VJ} = T_{VJM}$; $V_R = 0 \text{ V}$	t = 10 ms (50 Hz), sine t = 8.3 ms (60 Hz), sine	9100 A ² s 8830 A ² s
$(di/dt)_{cr}$	$T_{VJ} = T_{VJM}$; f = 50 Hz, $t_p = 200 \mu\text{s}$ $V_D = 2/3 V_{DRM}$ $I_G = 0.3 \text{ A}$ $di_G/dt = 0.3 \text{ A}/\mu\text{s}$	repetitive, $I_T = 60 \text{ A}$	150 A/ μs
		non repetitive, $I_T = I_{T(AV)M}$	500 A/ μs
$(dv/dt)_{cr}$	$T_{VJ} = T_{VJM}$; $R_{GK} = \infty$; method 1 (linear voltage rise)	$V_{DR} = 2/3 V_{DRM}$	1000 V/ μs
P_{GM}	$T_{VJ} = T_{VJM}$	$t_p = 30 \mu\text{s}$	10 W
$P_{G(AV)}$	$I_T = I_{T(AV)M}$	$t_p = 300 \mu\text{s}$	5 W
			0.5 W
V_{RGM}			10 V
T_{VJ}			-40...+140 °C
T_{VJM}			140 °C
T_{stg}			-40...+125 °C
F_C	Mounting Force		20...120/4.5...27 N/lbs
Weight			6 g

Features

- Thyristor for line frequency
- International standard package JEDEC TO-247
- Planar passivated chip
- Long-term stability of blocking currents and voltages

Applications

- Motor control
- Power converter
- AC power controller
- Switch-mode and resonant mode power supplies
- Light and temperature control

Advantages

- Easy to mount
- Space and weight savings
- Simple mounting

Symbol	Test Conditions	Characteristic Values	
I_R, I_D	$T_{VJ} = T_{VJM}; V_R = V_{RRM}; V_D = V_{DRM}$ $T_{VJ} = 25^\circ\text{C}$	≤ 10	mA
		≤ 0.2	mA
V_T	$I_T = 100 \text{ A}; T_{VJ} = 25^\circ\text{C}$	≤ 1.4	V
V_{T0}	For power-loss calculations only ($T_{VJ} = 125^\circ\text{C}$)	0.85	V
r_T		3.7	m Ω
V_{GT}	$V_D = 6 \text{ V}; T_{VJ} = 25^\circ\text{C}$ $T_{VJ} = -40^\circ\text{C}$	≤ 1.5	V
		≤ 1.6	V
I_{GT}	$V_D = 6 \text{ V}; T_{VJ} = 25^\circ\text{C}$ $T_{VJ} = -40^\circ\text{C}$	≤ 100	mA
		≤ 200	mA
V_{GD}	$T_{VJ} = T_{VJM}; V_D = 2/3 V_{DRM}$	≤ 0.2	V
I_{GD}		≤ 10	mA
I_L	$T_{VJ} = 25^\circ\text{C}; t_p = 10 \mu\text{s}$ $I_G = 0.45 \text{ A}; di_G/dt = 0.45 \text{ A}/\mu\text{s}$	≤ 450	mA
I_H	$T_{VJ} = 25^\circ\text{C}; V_D = 6 \text{ V}; R_{GK} = \infty$	≤ 200	mA
t_{gd}	$T_{VJ} = 25^\circ\text{C}; V_D = 1/2 V_{DRM}$ $I_G = 0.45 \text{ A}; di_G/dt = 0.45 \text{ A}/\mu\text{s}$	≤ 2	μs
R_{thJC}	DC current	0.32	K/W
R_{thJK}	DC current	0.47	K/W

PLUS247™ Outline

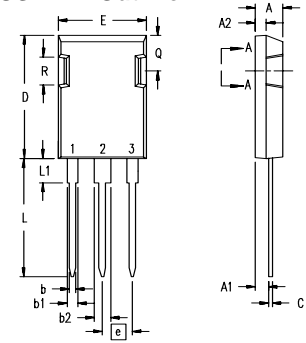

Terminals: 1 - Cathode
2 - Anode
3 - Gate
Tab - Anode

Dim.	Millimeter		Inches	
	Min.	Max.	Min.	Max.
A	4.83	5.21	.190	.205
A ₁	2.29	2.54	.090	.100
A ₂	1.91	2.16	.075	.085
b	1.14	1.40	.045	.055
b ₁	1.91	2.13	.075	.084
b ₂	2.92	3.12	.115	.123
C	0.61	0.80	.024	.031
D	20.80	21.34	.819	.840
E	15.75	16.13	.620	.635
e	5.45 BSC		.215 BSC	
L	19.81	20.32	.780	.800
L1	3.81	4.32	.150	.170
Q	5.59	6.20	.220	0.244
R	4.32	4.83	.170	.190

Leads and tab are solder plated.